

BIO-CEL® M+100

Submerged MBR Module for Wastewater Treatment

The BIO-CEL® MBR series is ideal for biological wastewater treatment in industrial and municipal applications. BIO-CEL MBR combines the benefits of traditional hollow fiber and plate and frame configurations without any of their inherent disadvantages. The module has an extremely high packing density due to the thin and self-supporting membrane sheets, and the laminate offers a self-healing mechanism.

MEMBRANE CHARACTERISTICS

Membrane	UV400T
Membrane Polymer	Polyvinylidene fluoride (PVDF)
Nominal Pore Size	0.06 µm
Preservative	Glycerine 20 % / Sodium benzoate 3 %

MODULE SPECIFICATIONS

Housing Material Options	Stainless Steel 1.4301/304 (V2A) On request: SS 1.4571/316Ti (V4A)
Drainage Layer	Polyester (PET)
Diffusors Material Options	Membrane hose: Silicone (SI) Support tube: Polypropylene (PP)
Nominal Membrane Area	100 m ² (1076 ft ²)

OPERATING PARAMETERS

pH Range	2.0 – 11.0
Temperature Range	5 – 40°C (41 – 104°F)
Maximum TMP during Filtration	- 400 mbar (-5.8 psi)
Maximum TMP during Regular Backwash	+150 mbar (+2.2 psi)
Recommended Air Scour Rate ^a	63 Nm ³ /h (37 SCFM)
Maximum Air Scour Rate ^a	80 Nm ³ /h (46 SCFM)
Recommended MLSS in MBR Tank	8 - 12 g/l
Maximum MLSS in MBR Tank	15 g/l
Maximum Particle Size in MBR Tank	2 mm
Total Chlorine Resistance	1,000,000 ppm•hr

a) Volumetric flow rate at standard conditions according to DIN ISO 2533:1979-12.

PHYSICAL DIMENSIONS

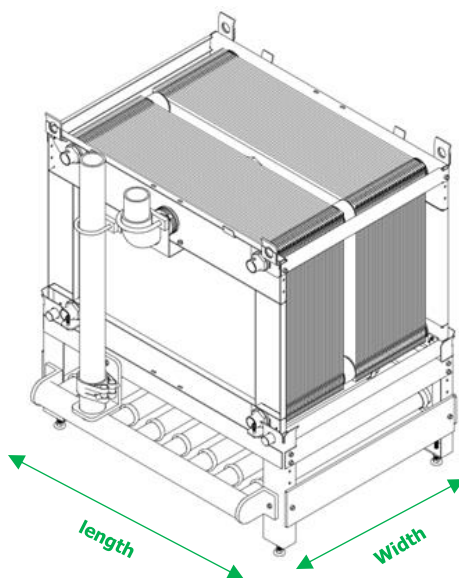

Dry Weight	150 kg (330 lbs)
Wet Weight without Solids	200 kg (440 lbs)
Maximum Load for Lifting ^b	500 kg (1102 lbs)
Length	1,275 mm (4.2 ft)
Width	1,130 mm (3.7 ft)
Height	1,498 mm (4.9 ft)
Filtration Tank Minimal Water Level	1698 mm (5.57 ft)
Connection for Permeate	PVC-U grey pipe end 90mm diameter SDR13,6/PN16 (DN80 Flange Adapter available)
Connection for Aeration	Polypropylene pipe end 90mm diameter SDR11/PN10 (DN80 Flange Adapter available)

b) Sludge deposit must be removed before lifting unit.

IMPORTANT INFORMATION

Scope of Supply, Accessories & Spare Parts: Please see BIO-CEL M+100 – Scope of Supply, Accessories and Spare Parts (TDS-WW031).

Storage & Handling: BIO-CEL MBR modules must be handled and stored appropriately to ensure proper operation and to prevent membrane damage. Please see BIO-CEL MBR – Storage Conditions (TB-WW002).

MANN+HUMMEL reserves the right to change specifications without prior notification.

Contact

Europe
 Germany: +49 611 962 6001
 Italy: +39 0721 1796201
 info.wfs@mann-hummel.com

Americas
 USA: +1 805 964 8003
 sales.mnus@microdyn-nadir.com

Asia
 APAC: +65 6457 7533
 info.wfs@mann-hummel.com
 China: +86 10 8413 9860
 waterchina@mann-hummel.com